

DS4 Controller Card Test Station

DS 9 MOPA Laser Test Station

Users Manual

© 2019-2024 by HALaser Systems GmbH

Table of Contents

1 Copyright.....	3
2 History.....	4
3 Safety.....	5
4 DS4 Controller Card Test Station.....	6
4.1 Overview.....	6
4.1.1 Features.....	6
4.2 Board And Connectors.....	7
4.2.1 Scanner Section Connectors.....	8
4.2.2 Laser Section Connectors.....	9
4.2.3 Digital IO Section Connectors.....	10
4.2.4 Intelli IO Section Connectors.....	11
4.2.5 Miscellaneous Section Connectors.....	12
4.3 Testing Procedure.....	13
5 DS9 MOPA Laser Card Test Station.....	14
5.1 Overview.....	14
5.1.1 Features.....	14
5.2 Board And Connectors.....	15
5.2.1 Digital (LP8) MOPA Laser Section.....	15
5.2.2 Analogue MOPA Laser Section.....	16
APPENDIX A – Board dimensions.....	19

1 Copyright

This document is © by HALaser Systems.

E1701, E1702 boards, their hardware and design are copyright / trademark / legal trademark of HALaser Systems GmbH.

E1803D boards, their hardware and design are copyright / trademark / legal trademark of HALaser Systems GmbH.

All other names / trademarks are copyright / trademark / legal trademark of their respective owners.

3 Safety

The hardware described here is an electrostatic sensitive device. This means it can be damaged by common static charges which build up on people, tools and other non-conductors or semiconductors. To avoid such a damage, it has to be handled with care and including all relevant procedures (like proper grounding of people handling the devices, shielding/covering to not to let a person touch the device unwanted, proper packaging in ESD-bags, ...). For more information please refer to related regulations and standards regarding handling of ESD devices.

The hardware described here is a component which is intended to be used as part of a larger device, e.g. for integration in other test equipment with own housing.

This document describes the DS4 and DS9 Test Station hardware but may contain errors or may be changed without further notice.

4 DS4 Controller Card Test Station

4.1 Overview

This document describes the DS4 Test Station board, its electrical characteristics and usage. This board is designed to check signals and hardware of different controller boards available from HALaser Systems. It acts as some kind of adapter to the various connectors and interfaces of the supported boards, gives a quick overview about available signals by signalling LEDs and offers easy to access test- and measuring points for use with a multimeter and/or an oscilloscope.

It is not a ready-to-use device but a component which is intended to be integrated in larger devices or to be operated with an own housing.

4.1.1 Features

The DS4 Test Station board provides the following features:

- Complete testing of an E1803D controller including XY2-100/XY3-100 interface, digital interface, laser interface and Intelli-IO Extension board (serial interface not yet covered)
- Complete testing of an E1702S scanner controller card including XY2-100/XY3-100/NX-02 interface and LP8 signals (all these signals require an adapter) and the Digi IO extension board
- Partial testing of an E1701C controllers LP8 extension and Digi IO extension boards
- Complete testing of E1701D controller board including XY2-100/XY3-100 baseboard, LP8 extension and Digi IO extension board
- Partial testing of an E1701A controllers LP8 extension and Digi IO extension boards
- Complete testing of an E1701M controller

PLEASE NOTE: testing can be done with exactly one board at the same time, neither is it allowed to connect more than one board or is it allowed to mix different types of boards and to try to test them at the same time. Doing so can cause an irreversible damage to all connected boards.

Here testing includes:

- quick and rough visual inspection of output signals
- detailed measurement of output signals at easy accessible measurement-points
- easy setting and testing of digital input signals via integrated switches
- easy setting/varying of analogue input values via integrated trimmers
- easy handling
- can be connected quickly to the controllers via flat-belt cables

4.2 Board And Connectors

The board provides several connectors which belong to their counterparts on the controller/extension. For each of these connectors there exists a section on the board which provides LEDs, measuring points, buttons and/or trimmers. For a better understanding these sections and the related connectors are marked with colours:

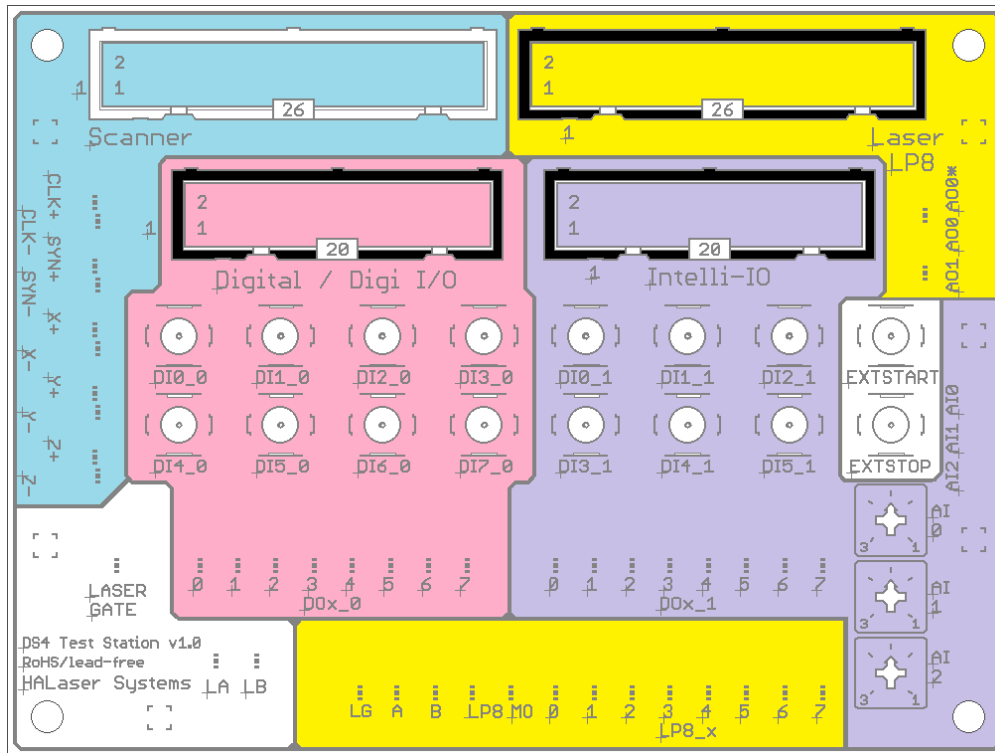

Following sections exist on the test board:

1. Scanner section (marked in **turquoise** in image above), to be connected with the (optionally) white XY2-100/XY3-100/NX-02 interface connector of E1701D/E1803D/E1702S
2. Laser section (marked in **yellow** in image above), to be connected with the black LP8 extension connector of E1701A, E1701C or E1701D or with the laser interface connector of E1803D or with the LP8 signals of the E1702S
3. Digital IO section (marked in **pink** in image above), to be connected with the black Digi IO extension connector of E1701A, E1701C, E1701D, E1702S or with the E1701M or with the black digital interface connector of E1803D
4. Intelli-IO (marked in **purple** in image above), to be connected with the black connector of the Intelli-IO extension which is optional to the E1803D
5. Miscellaneous (marked in white in image above), used in multiple ways depending on what hardware is connected exactly

Most signals are visualised by a LED which – in case of normal operation – shows a typical lighting/flickering. This gives a first, rough overview if the signal is correct. To verify this, the related signal can be measured using the related measuring point which is always located close to the LED. Appropriate GND-points are spread over the whole board, they are larger, round points and can be used independent from a logical section the measured signal belongs to. In image below the GND-points are marked in red:

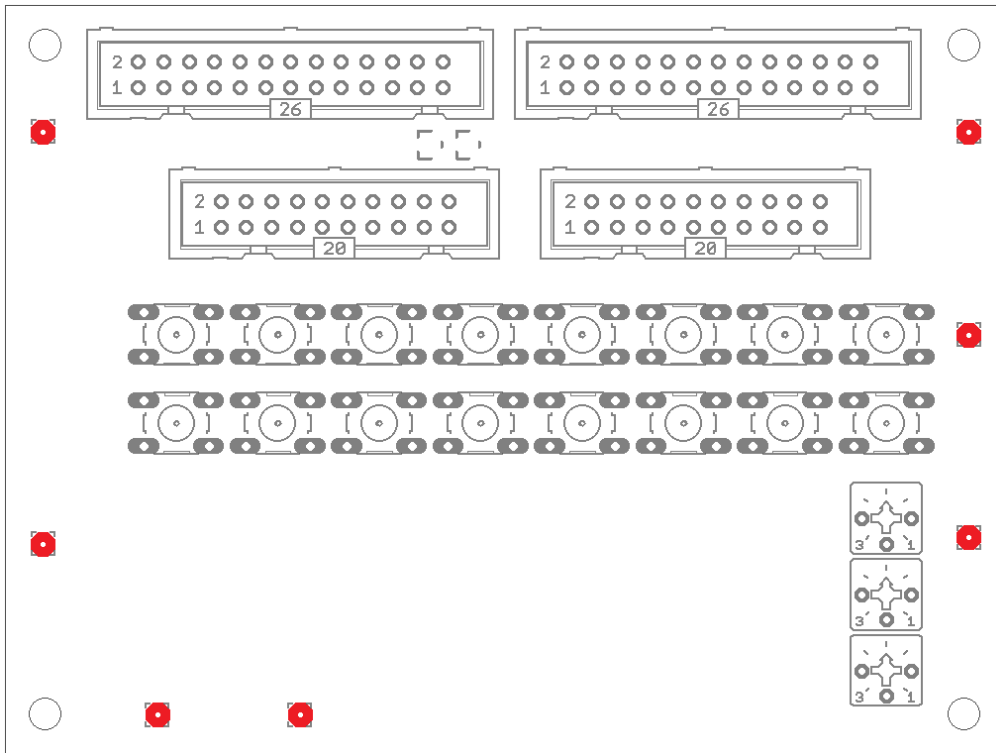

The different sections as mentioned above provide interfaces and functionalities as described in following sections:

4.2.1 Scanner Section Connectors

When connected to the XY2-100 interface of E1701D/E1702S/E1803D, here following signals are available:

Signal Name	Label on board	LED	Element
XY2-100 CLK+	CLK+	Red	Test point
XY2-100 CLK-	CLK-	Red	
XY2-100 SYNC+	SYN+	Yellow	Test point
XY2-100 SYNC-	SYN-	Yellow	
XY2-100 X+	X+	Yellow	Test point
XY2-100 X-	X-	Yellow	
XY2-100 Y+	Y+	Yellow	Test point
XY2-100 Y-	Y-	Yellow	
XY2-100 Z+	Z+	Yellow (always off for E1702S)	Test point
XY2-100 Z-	Z-	Yellow (always off for E1702S)	
Common Ground	GND		Test point

Except for the SYNC-signal, for these LEDs one rule is mandatory: pairs of signal always should show the same brightness on the related LED. When “+” and “-” channel of a signal are fundamental different, one can assume there is a problem with the differential signal.

When connected to the XY3-100 interface of E1701D/E1702S/E1803D, here following signals are available:

Signal Name	Label on board	LED	Element
XY3-100 SYNC+	CLK+	Red	Test point
XY3-100 SYNC-	CLK-	Red	
XY3-100 CLK+	SYN+	Yellow	Test point
XY3-100 CLK-	SYN-	Yellow	
XY3-100 X+	X+	Yellow	Test point
XY3-100 X-	X-	Yellow	
XY3-100 Y+	Y+	Yellow	Test point
XY3-100 Y-	Y-	Yellow	
XY3-100 Z+	Z+	Yellow (always off for E1702S)	Test point
XY3-100 Z-	Z-	Yellow (always off for E1702S)	
Common Ground	GND		Test point

Except for the SYNC-signal, for these LEDs one rule is mandatory: pairs of signal always should show the same brightness on the related LED. When “+” and “-” channel of a signal are fundamental different, one can assume there is a problem with the differential signal.

When connected to the NX-02 interface of E1702S, here following signals are available:

Signal Name	Label on board	LED	Element
NX-02 DATA+	CLK+	Red	Test point
NX-02 DATA--	CLK-	Red	
unused	SYN+	always off	
unused	SYN-	always off	
unused	X+	always off	
unused	X-	always off	
unused	Y+	always off	
unused	Y-	always off	
unused	Z+	always off	
unused	Z-	always off	
Common Ground	GND		

For these LEDs one rule is mandatory: they always should show the same brightness. When “+” and “-” channel of a signal are fundamental different, one can assume there is a problem with the differential signal.

4.2.2 Laser Section Connectors

When connected to the LP8 extension (black connector of LP8 extension board for E1701A, E1701C or E1701D) or to the laser interface (black connector of E1803D) or the LP8 signals of E1702S, here following signals are available:

Signal Name	Label on board	LED	Element
LaserA	A	yellow	
LaserB	B	yellow	
Laser Gate	LG	red	
LP8 Latch	LP8 Latch-	red	Test point
Master Oscillator	MO	yellow	Test point
LP8_0	LP8_x / 0	yellow	Test point
LP8_1	LP8_x / 1	yellow	Test point
LP8_2	LP8_x / 2	yellow	Test point
LP8_3	LP8_x / 3	yellow	Test point
LP8_4	LP8_x / 4	yellow	Test point
LP8_5	LP8_x / 5	yellow	Test point
LP8_6	LP8_x / 6	yellow	Test point
LP8_7	LP8_x / 7	yellow	Test point
Analogue output AO0 (E1701x LP8 extension)	AO0*	red	Test point
Analogue output AO0 (E1803D laser interface)	AO0	red	Test point
Analogue output AO1 (E1803D laser interface)	AO1	red	Test point
Common Ground	GND		Test point

4.2.3 Digital IO Section Connectors

When connected to the Digi IO extension (black connector on Digi IO extension board of of E1701A, E1701C, E1701D or E1702S), or to the E1701M (black connector) or to the digital interface (black connector of E1803D), here following signals are available:

Signal Name	Label on board	LED	Element
DIn0 input	DI0_0		button
DIn1 input	DI0_1		button
DIn2 input	DI0_2		button
DIn3 input	DI0_3		button
DIn4 input	DI0_4		button
DIn5 input	DI0_5		button
DIn6 input	DI0_6		button
DIn7 input	DI0_7		button
DOut0 output	DOx_0/0	green	
DOut1 output	DOx_0/1	green	
DOut2 output	DOx_0/2	green	
DOut3 output	DOx_0/3	green	
DOut4 output	DOx_0/4	green	
DOut5 output	DOx_0/5	green	
DOut6 output	DOx_0/6	green	
DOut7 output	DOx_0/7	green	

4.2.4 Intelli IO Section Connectors

When connected to the Intelli-IO extension of E18013D (black connector on optional extension board) following signals are available:

Signal Name	Label on board	LED	Element
DIn0 input	DI1_0		button
DIn1 input	DI1_1		button
DIn2 input	DI1_2		button
DIn3 input	DI1_3		button
DIn4 input	DI1_4		button
DIn5 input	DI1_5		button
DOut0 output	DOx_1/0	green	
DOut1 output	DOx_1/1	green	
DOut2 output	DOx_1/2	green	
DOut3 output	DOx_1/3	green	
DOut4 output	DOx_1/4	green	
DOut5 output	DOx_1/5	green	
DOut6 output	DOx_1/6	green	
DOut7 output	DOx_1/7	green	
AIn0 input	AI0		Trimmer and test point
AIn1 input	AI1		Trimmer and test point
AIn2 input	AI2		Trimmer and test point
Common Ground	GND		Test point

4.2.5 Miscellaneous Section Connectors

Board	Signal Name	Label on board	LED	Element
E1701D/E1702S Baseboard	LaserGate	LG	red	
E1701D/E1702S Baseboard	LaserA	LA	yellow	Test point
E1701D/E1702S Baseboard	LaserB	LB	yellow	Test point
E1701D/E1702S Baseboard and E1803D laser interface	ExtStart input	EXTSTART		Button
E1701D/E1702S Baseboard and E1803D laser interface	ExtStop input	EXTSTOP		Button
Common Ground	GND			Test point

4.3 Testing Procedure

The DS4 Test Station makes it easy to test controller boards and their interfaces as well as the emitted signals. This is useful not only for checking if a hardware is still working correctly but also for evaluating signals in order to see if the software configuration is correct and even to evaluate if a functional problem may be caused by a wrong wiring.

For this a typical test procedure looks like this:

1. Disconnect the related board from its external hardware (like lasers or scanners)
2. Connect the board to the DS4 Test Station board via an appropriate flat-belt cable
PLEASE NOTE: ensure to connect the correct boards with the appropriate connectors of the DS4, otherwise both, the board to be tested and the DS4 can be damaged!
3. Start operation by invoking a (looped) marking cycle
4. Now a quick evaluation of correctness of the signals is possible via the LEDs, they should be lit more or less bright depending on what signal is applied and how the controller is working at the moment
PLEASE NOTE: the LEDs give only a rough overview and are useful for a first, quick check only, when they are lit or off as expected, it does not necessarily mean, the related signal is correct!
5. For deeper inspection of the signal, use an oscilloscope and evaluate the related signals by measuring them at the test points which are assigned to the functions to be tested
6. Additionally: digital inputs can be set by pressing the related buttons, analogue input signals can be fed into the Intelli-IO-Extension by modifying the position of the trimmers

5 DS9 MOPA Laser Card Test Station

5.1 Overview

This document describes the DS9 Test Station board, its electrical characteristics and usage. This board is designed to check signals and hardware of MOPA lasers, both with digital (LP8) and analogue (0..4V or 0..10V) power control. It can be used as pass-through board which is connected to a scanner controller card on one side and to the laser on the other side. This way it is possible to check and measure the laser signals directly during the operation, giving a quick overview about available signals by signalling LEDs and offers easy to access test- and measuring points for use with a multimeter and/or an oscilloscope.

It is not a ready-to-use device but a component which is intended to be integrated in larger devices or to be operated with an own housing.

5.1.1 Features

The DS9 Test Station board provides the following features:

- Complete testing of all MOPA lasers with digital power control that make use of the standard D-SUB25 connectors
- Complete testing of all MOPA lasers with analogue power control that make use of the standard D-SUB25 connectors

PLEASE NOTE: testing can be done with exactly one laser at the same time. Although the board contains two separate sections for MOPA lasers with analogue and digital power control, they would have been connected via their ground-signal when being used at the same time. This may lead to unwanted effects, undefined behaviour and in worst case damage of connected components.

Here testing includes:

- quick and rough visual inspection of output signals
- detailed measurement of output signals at easy accessible measurement-points
- easy handling
- can be connected quickly to laser and controller via flat-belt cables or standard 1:1 D-SUB25 cables

5.2 Board And Connectors

The board is divided into two separate sections, one for MOPA-lasers that require digital (LP8) power control and one for MOPA-lasers that require analogue power control. The D-SUB25 connectors of each section are directly connected to each other and provide a 1:1 pass-through so that it is possible to place the DS9 testboard in between the connection from controller card to laser. For each of these laser types there exists a section on the board which provides these D-SUB25 interfaces as well as LEDs and measuring points. For a better understanding these sections and the related connectors are marked with colours:

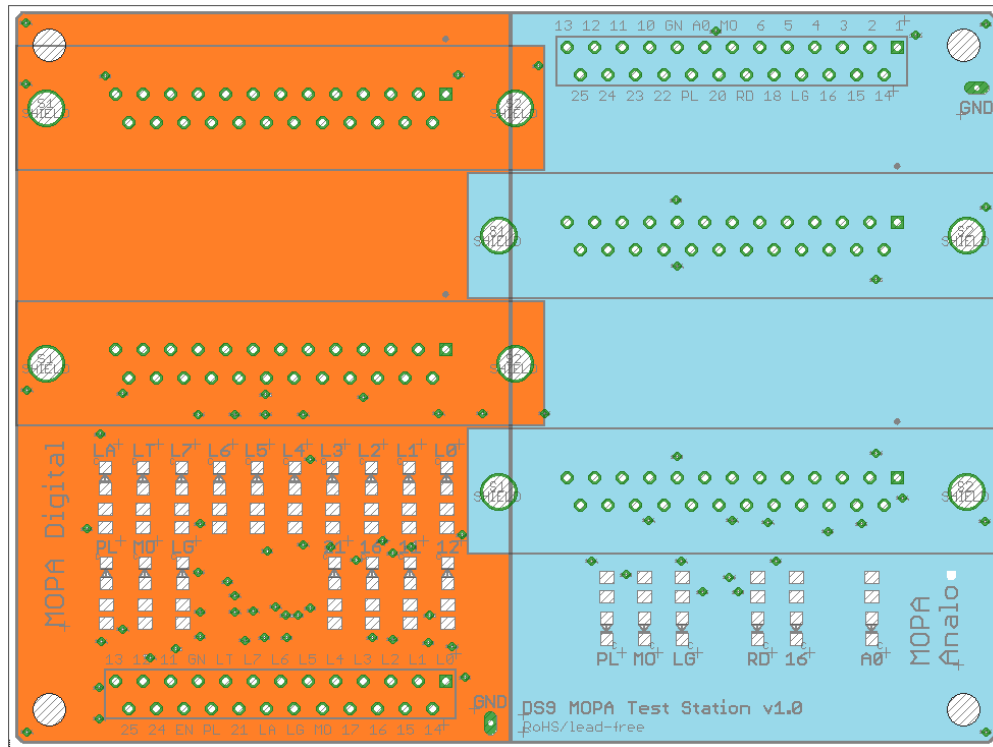

Following sections exist on the test board:

1. The digital (LP8) type MOPA lasers can be used with the left section which is marked in **orange**
2. The analogue type MOPA lasers can be used with the right section which is marked in **turquoise** in image above

Most signals are visualised by a LED which – in case of normal operation – shows a typical lighting/flickering. This gives a first, rough overview if the signal is correct. To verify this, the related signal can be measured using the related measuring point on top/bottom of the board. Appropriate GND-points are available close to these measuring points.

5.2.1 Digital (LP8) MOPA Laser Section

From top to bottom the digital MOPA laser section provides the following access possibilities:

- D-SUB25-connector for input/output (to connect scanner controller/laser with)
- D-SUB25-connector for output/input (to connect laser/scanner controller with)
- State-LEDs which give a quick overview about signals and operation
- measuring points for detailed checking of signals using e.g. an oscilloscope

Here following signals are available as LED/at the measuring points:

Pin number	Label	Signal
1	L0	LP8 bit 0
2	L1	LP8 bit 1
3	L2	LP8 bit 2
4	L3	LP8 bit 3
5	L4	LP8 bit 4
6	L5	LP8 bit 5
7	L6	LP8 bit 6
8	L7	LP8 bit 7
9	LT	LP8 Latch
10	GN	Ground
11	11	Error bit 11
12	12	Error bit 12
13	13	
14	14	
15	15	
16	16	Error Bit 16
17	17	
18	MO	Main Oscillator / emission control
19	LG	LaserGate / emission modulation
20	LA	LaserA / PWM / pulse repetition rate
21	21	Error bit 21
22	PL	Pilot laser / aiming beam
23	EN	Enable / emergency stop
24	24	
25	25	

5.2.2 Analogue MOPA Laser Section

From top to bottom the analogue MOPA laser section provides the following access possibilities:

- measuring points for detailed checking of signals using e.g. an oscilloscope
- D-SUB25-connector for input/output (to connect scanner controller/laser with)
- D-SUB25-connector for output/input (to connect laser/scanner controller with)
- State-LEDs which give a quick overview about signals and operation

Here following signals are available as LED/at the measuring points:

Pin number	Label	Signal
1	1	
2	2	
3	3	
4	4	
5	5	
6	6	
7	MO	Main Oscillator / Emission Control
8	A0	Analogue power / pump bias
9	GN	Ground
10	10	
11	11	
12	12	
13	13	
14	14	
15	15	
16	16	
17	LG	LaserGate / Modulation
18	18	
19	RD	Ready
20	20	
21	PL	Pilot laser / aiming beam
22	22	
23	23	
24	24	
25	25	

Pin number	Label	Signal
1	L0	LP8 bit 0
2	L1	LP8 bit 1
3	L2	LP8 bit 2
4	L3	LP8 bit 3
5	L4	LP8 bit 4
6	L5	LP8 bit 5
7	L6	LP8 bit 6
8	L7	LP8 bit 7
9	LT	LP8 Latch
10	GN	Ground
11	11	Error bit 11
12	12	Error bit 12
13	13	
14	14	
15	15	
16	16	Error Bit 16
17	17	
18	MO	Main Oscillator
19	LG	LaserGate / Modulation
20	LA	LaserA / PWM
21	21	Error bit 21
22	PL	Pilot laser pin
23	EN	Enable
24	24	
25	25	

APPENDIX A – Board dimensions

Board dimension drawing, all values are given in unit mm.



Alphabetical Index

A	
Analogue.....	16
D	
Digi IO.....	6
Digital.....	15
dimension drawing.....	19
dimensions.....	19
E	
E1701A.....	6
E1701C.....	6
E1701D.....	6
E1701M.....	6
E1803D.....	6
electrostatic sensitive device.....	5
ESD.....	5
L	
LP8.....	6, 15
M	
MOPA.....	15f.
N	
NX-02.....	6
X	
XY2-100.....	6
XY3-100.....	6