

**HALscan .20  
XY3-100 Scanheads**



**Users Manual**

© 2020-2023 by HALaser Systems

# Table Of Contents

1 Copyright.....	3
2 History.....	4
3 Safety.....	5
3.1 Transport and Storage.....	6
4 Overview.....	7
4.1 Type Code.....	7
5 Features and Technical Data.....	8
6 Functional Description.....	10
7 Electrical Connection.....	11
8 Initial Operation.....	12
9 Mechanical Specifications HALscan 10.20/10N20.....	13
10 Mechanical Specifications HALscan 16.20/16N20.....	14
11 Mechanical Specifications HALscan 20.20/20N20.....	15
12 Mechanical Specifications HALscan 30.20/30N20.....	16

# 1 Copyright

This document is © by HALaser Systems. This document and the described hardware is subject to modifications. Errors expected. This document is subject to change without prior notice. The given technical data base on specifications of the vendor of components or parts of the hardware. Tolerances are to be expected. Duplication of this manual in whole or in part or reproduction by any means are forbidden without the prior, written consent of HALaser Systems.

HALscan scanheads, their hardware and design are copyright by HALaser Systems.

## 2 History

Date	Changes in document
08/2023	Type label description extended
02/2023	Non-ambiguous naming scheme introduced
02/2023	Power values adjusted
12/2022	Description of HALscan 20X20 and HALscan 30X20 added
12/2022	Technical data clarified
11/2022	Description of HALscan 16X20 added
07/2022	Added missing backchannel-description in pinout
07/2021	Naming scheme explanation added
06/2021	XY3-100 certified logo added
10/2020	Resolution value in technical data corrected
08/2020	Added description of supported XY3-100 commands
08/2020	Power supply specifications updated and clarified
07/2020	Initial version

### 3 Safety

The hardware described within this document is designed to control a laser scanner system. Laser radiation may effect a person's health or may otherwise cause damage. Prior to installation and operation compliance with all relevant safety regulations including additional hardware-controlled safety measures has to be secured. The client shall solely be responsible to strictly comply with all applicable and relevant safety regulations regarding installation and operation of the system at any time.

Beside of that some laser equipment can be damaged in case it is controlled with wrong signals or signals outside a given specification. Thus it is highly recommended to check the output generated by this hardware using e.g. an oscilloscope to avoid problems caused by wrong configurations. This should be done prior to putting a system into operation for the first time, whenever some parameters have been changed or whenever any kind of software update was installed.

The hardware described here is shipped without any cover and without prefabricated equipment for electric installation. It is intended to be integrated in machines or other equipment. It is not a device for use "as is", but a component which is intended to be used as part of a larger device, e.g. for integration in a machine with own housing. Prior to operation compliance with all relevant electric / electromagnetic safety regulations including additional hardware-controlled safety measures has to be secured. The client shall solely be responsible to strictly comply with all applicable and relevant regulations regarding installation and operation of the system at any time.

The EMC Directive (2014/30/EU) does not apply to this hardware as it is not intended for an end user (a person without knowledge of EMC) and as it is not otherwise made available on the market.

The Low Voltage Directive (2014/35/EU) does not apply to this hardware as the voltage supply is below the 50V AC / 75V DC limit.

The scanhead described here is designed to deflect an input laser beam and output it again. It can't block or weaken the laser beam. To prevent unwanted emission of the laser beam, above a particular danger class the laser device must be fitted with a shutter or any other suitable device. This laser device must be of sufficient quality so that the laser beam can only be emitted at the beam output on the deflection unit. Proper warning signs have to be attached at the machine or device where this scanhead is used to clearly inform any user about all possible dangerous operations.

The surfaces of the scanheads mirrors are extremely sensitive and should not be touched in any way and may only be cleaned by experienced personnel. Thus we strongly recommend sending the deflection unit in to HALaser Systems for the mirrors to be cleaned, as opening of the scanhead by unauthorized personnel voids the warranty.



To improve the optical properties of the mirrors, lenses or protection glasses, different material are applied as coatings. Some of them may be potentially hazardous to health if inhaled or swallowed. Under normal circumstances, no special precautions are necessary when handling or storing mirrors, lenses or protection glasses with such specific coatings.

In case of damage to such a component and/or coating, follow these instructions:

- switch off the laser immediately
- avoid inhaling dust of possibly broken or burned components
- leave the room for at least 30 minutes
- wear gloves and a mouth protector while performing all the subsequent steps
- pack the optical elements in an airtight sealed plastic container, in case of fragments carefully collect up all fragments
- clean all contaminated components and surfaces with a damp cloth and pack the cleaning cloths in a sealed plastic container too
- ensure professional disposal of the container

Please note: these general instructions are relevant only in case special coatings are used on any of the optical components. This includes also third party components which may be operated together with the HALscan scanhead (like F-Theta lenses or protection glasses). For detailed information about the used coatings, their dangerousness and for specific handling instructions in case of normal operation or damages, please contact the supplier of the related components.

### **3.1 Transport and Storage**

During transport or storage at least the optical in- and outputs should be covered to protect the mirrors and galvos from dust and humidity. Furthermore there should be no larger vibrations and it has to be ensured nobody and nothing can touch the mirrors or the galvos. Corrosive and/or wet and or condensing environments should be avoided in general not only during transport and storage but also during operation.

## 4 Overview

This document describes the HALscan scanheads, their characteristics and usage.

These scanheads are components according to Low Voltage Directive (LVD) 2006/95/EC of the European Union and related domestic directives, thus they will be used as part of a laser scanning system which itself can be part of a machine.

This document contains important information on qualified and safe handling of HALscan scanheads. Therefore you should familiarize yourself with the content of this manual before using such a scanhead for the first time. Furthermore this manual must be accessible to anyone who will be involved in developing, installing or using a laser device featuring a HALscan scanhead. When a scanhead is sold on, this operating manual or an authorized copy must be passed on with it.

### 4.1 Type Code

Scanheads of type "HALscan" make use of a defined name scheme which can be interpreted as follows:

**HALscan aaIrr**

**HALscan** – the general name of the scanhead

**aa** – aperture size in mm

**I** – interface to scanner controller card:

“.” or “**x**” – XY3-100 interface

“**N**” – NX-02 interface

**rr** – digital resolution of the input, optional, can be dropped together with the generic placeholder

## 5 Features and Technical Data

HALscan scanheads offers the following interfaces, functions and features:



1. XY3-100 data interface and power connector
2. Beam entrance
3. M85x1 lens ring (can be removed)
4. M5 laser and head mounting screw holes

Model	<b>HALscan 10.20</b>	<b>HALscan 16.20</b>	<b>HALscan 20.20</b>	<b>HALscan 30.20</b>
Interface	two-channel XY3-100 (2D)			
Model	<b>HALscan 10N20</b>	<b>HALscan 16N20</b>	<b>HALscan 20N20</b>	<b>HALscan 30N20</b>
Interface	Two-channel NX-02 (2D)			
Digital resolution/ accuracy	20 bits <sup>1)</sup>			
Power supply requirements	+ -15 V / 2 A	+ -15 V / 3 A		
Idle power consumption (no galvo movements)	< 7 W	< 10 W		
Mirror size	10 mm	16 mm	20 mm	30 mm
Maximum Laser Power	50 W <sup>2)</sup> / 90 W <sup>2)3)</sup>	250 W @ 10600 nm (CO <sub>2</sub> ) 500 W @ 1064 nm <sup>2)</sup> 1500 W @ 1064 nm CW <sup>2)</sup>	400 W @ 10600 nm (CO <sub>2</sub> ) 2 kW @ 1064 nm <sup>2)</sup>	500 W @ 10600 nm (CO <sub>2</sub> ) 4 kW @ 1064 nm <sup>2)</sup>
Screw thread for optics	M 79 x1 (M 85 x1 with included lens ring)	M 85 x1		M 95 x1
Positioning speed	>7 m/sec		>5 m/sec	>4 m/sec
Marking speed	up to 3,5 m/sec	> 2,8 m/sec	> 2,2 m/sec	> 2 m/sec
Precision writing	650 cps <sup>4)</sup>	450 cps <sup>4)</sup>	320 <sup>4)</sup>	260 <sup>4)</sup>
Resolution	1 µrad	1,1 µrad	1,15 µrad	1,15 µrad
Total scanning angle	40 degrees			
Scanner Lag (Tracking error)	0,18 msec	0,26 msec	0,32 msec	0,58 msec
1% step response	0,36 msec			



setting to 0,1% fs				
Scale drift	<80 ppm/°C	<=100 ppm/°C		
Zero drift	<50 µrad/°C			
Long term drift	<0.3 mrad			
Weight	1,7 kg (with lens ring)	3,3 kg (with lens ring)	4,2 kg	4,5 kg
Ambient temperature	25 °C +- 10 °C <sup>3)</sup>			
Cooling	Air (passive)	Air (passive), optionally water		

<sup>1)</sup> to gain full 20 bits accuracy at the output, marking speeds and in-polygon-delay need to be adjusted properly

<sup>2)</sup> at 1064 nm, requires precise central justification of the laser and utilisation of full available mirror surface; customer has to take care the laser does not hit the mounting points of the mirrors, this would lead to damage of the scanhead together with a loss of any kind of warranty. Depending on used pulses and frequency additional cooling of the head may be necessary also when operated under recommended temperature conditions.

<sup>3)</sup> requires specific, high-power mirrors.

<sup>4)</sup> unit cps / characters per second describes the number of average characters that can be marked without distortions within one second when using a single-line font and characters with a height of 1 mm (height in case of a F160 lens at nominal working area size)

Water cooling (if available):

- Pressure: 10 kPa
- Flow: 2,5 l/min
- Outer tube diameter: 6 mm
- Refrigerant: distilled water

## 6 Functional Description

A HALscan scanhead can be used to deflect a laser beam in X and Y direction. This results in an area within which a laser can be moved to any position. This area is known as "marking field". This operation is performed by two mirrors, each of which is moved by a galvanometer scanner. The scanhead itself provides a beam input, into which the laser beam is fed, and a beam output, through which the laser beam is emitted from the unit after deflection. Only suitable lasers have to be fed into the beam input. Depending on some additional equipment and the working environment, the beam output is either open or fitted with an F-Theta lens or protection glass.

Comparing to other scanheads, the HALscan can be operated in a way where it shows a nearly linear behaviour (see "auto calibration" option below). This means, in this operation mode, there exists no nameable pillow distortion caused by the mechanical structure of the scanhead and the geometries of the mirrors. Thus for many applications no correction table is needed. This is true as long as no F-Theta lens<sup>1)</sup> is used. Independent from that, the user is still free to make use of correction files in order to get specific shapes of the output or to gain an additional level of accuracy for special applications.

The HALscan scanhead supports the following XY3-100 features and commands:

- 24 bit XY3-100 raw frames with included 20 bit position data
- auto-calibration (`XY3_CMD_AUTOCALIB_ON/XY3_CMD_AUTOCALIB_OFF`); this function is disabled by default and adjusts the received position data permanently to have a linear behaviour of the scanhead
- temperature compensation (`XY3_CMD_TEMPCOMP_ON/XY3_CMD_TEMPCOMP_OFF`); this function is disabled by default, when this function is enabled, the internal temperature is measured and the temperature drift of the scanhead is adjusted permanently to stay as close to zero as possible
- backchannel-data, permanent transfer of state information via F-/F+ pins

Please check the manual of the used scanner controller card about how these modes can be set/reset.

<sup>1)</sup> An F-Theta lens is an optical component which is specially designed for use with 2-axis scanheads. It focuses the laser beam at optimum quality on any position in the marking field with a nearly constant beam length at all marking positions. Thus the desired marking field has to fit to an F-Theta lenses nominal size.

# 7 Electrical Connection

The HALscan scanheads all are compatible with the industry standard XY3-100 data interface that is available on several industry-grade scanner controller cards (like E1803D controller). The pinout and voltage supply connections are shown below and require a male D-SUB25 connector:

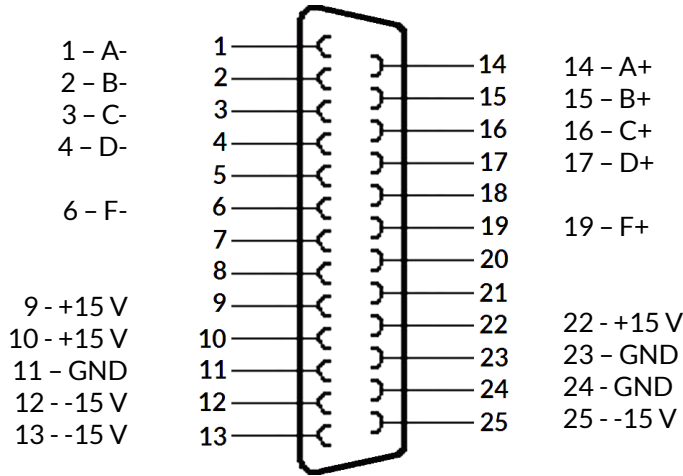

The power supply needs to be a balanced +/- 15 V (+/- 0.5 V tolerance).

 **ATTENTION:** When the scanhead is powered separately, power has to be fed into scanhead only but never into the connected controller card!

 **ATTENTION:** During operation it has to be ensured the symmetric power with +15 V and -15 V is available all the time. Unplugging the D-SUB25 connector during operation or switching off one of both power lines for a longer time may damage electronics and - as follow up - the mirrors too.

## 8 Initial Operation

Since the HALscan scanheads do not have a nameable startup-procedure, putting them into operation consists of a few steps only:

1. power up HALscan and if necessary the connected scanner controller card
2. wait a few seconds until scanner is initialised
3. start sending data from the scanner controller card to the HALscan scanhead

For security reasons it is recommended to not to send any data to the HALscan head while it is still turned off, causing a situation where it may start up in the middle of an already running data transmission. This may lead to the first valid position command received is at an extreme and unexpected position. In such a situation, when it jumps to an extreme scanner position immediately, this may cause damage to the galvos and/or mirrors.

The same is true during operation: when the connection has been interrupted (e.g. because the DB25 connector cable was removed), it is not recommended to simply plug it back in, as this may lead to hard jumps to extreme positions too. In this case it is also recommended to power down the whole system and put it back into operation using the sequence as described above.

# 9 Mechanical Specifications HALscan 10.20/10N20

Dimensions:

W x H x D: 120 x 95 x 96 mm

Size (without lens ring)

W x H x D: 120 x 122 x 96 mm

Size (with lens ring)

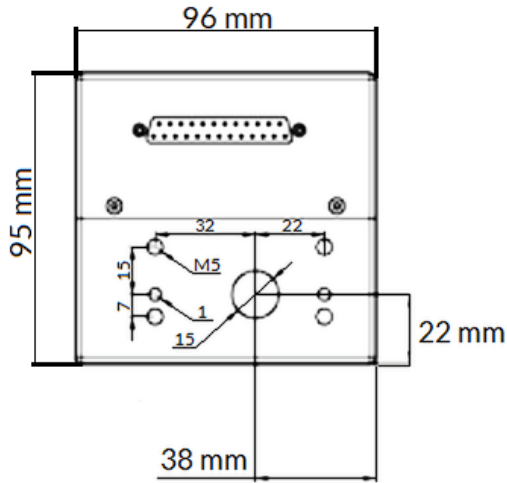

Drawing Beam Entrance Side

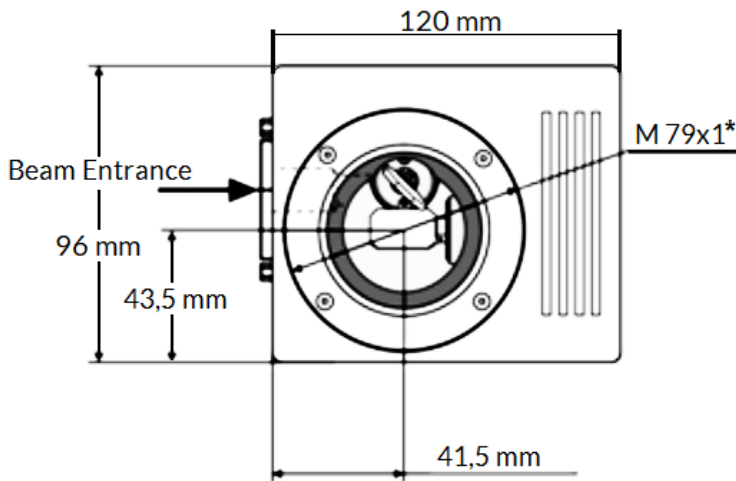

Drawing Beam Exit Side

# 10 Mechanical Specifications HALscan 16.20/16N20

Dimensions:

W x H x D: 156 x 121 x 115 mm

Size (without lens ring and without optional water cooling connection)

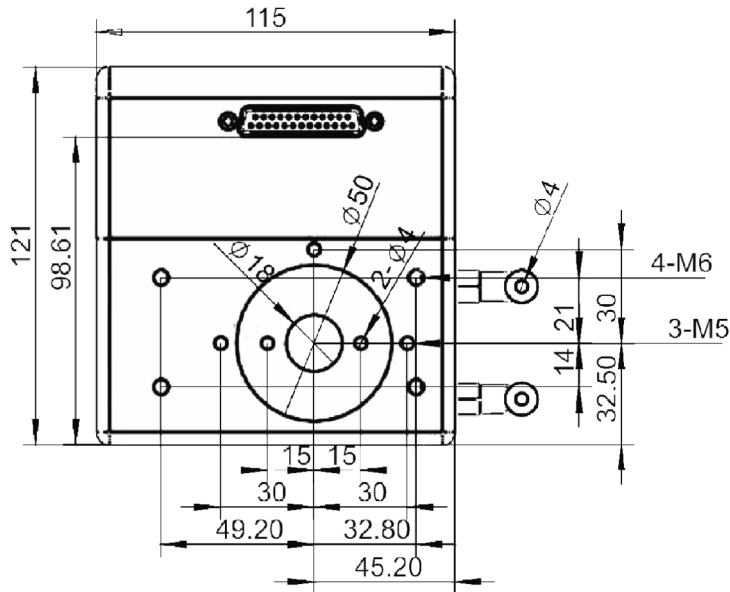

rawing Beam Entrance Side

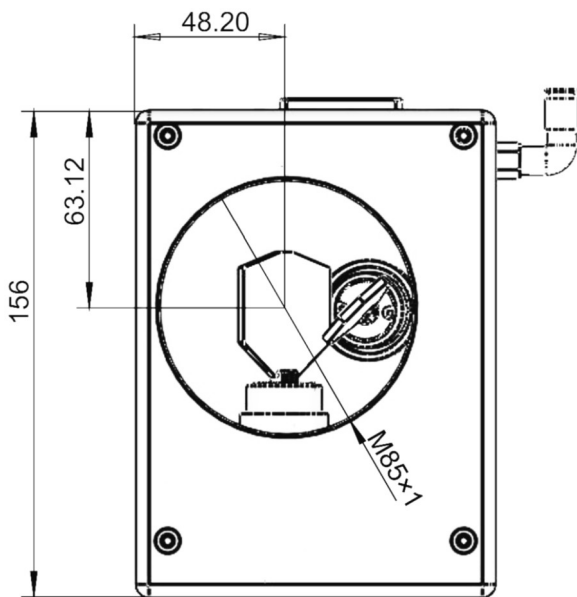

Drawing Beam Exit Side

# 11 Mechanical Specifications HALscan 20.20/20N20

Dimensions:

W x H x D: 169 x 148 x 120 mm

Size

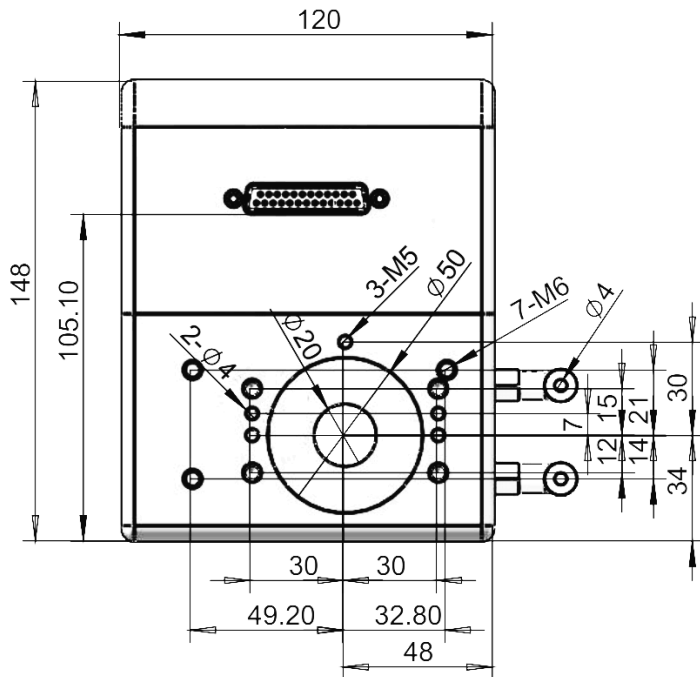

Drawing Beam Entrance Side

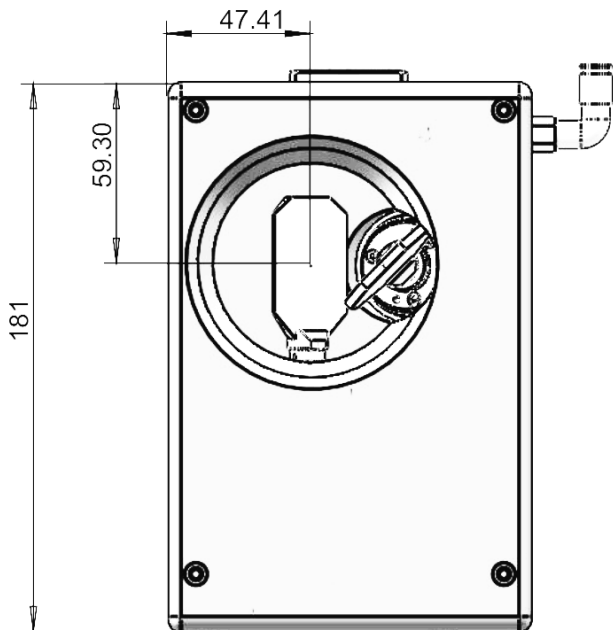

Drawing Beam Exit Side

# 12 Mechanical Specifications HALscan 30.20/30N20

Dimensions:

W x H x D: 185 x 148 x 140 mm

Size

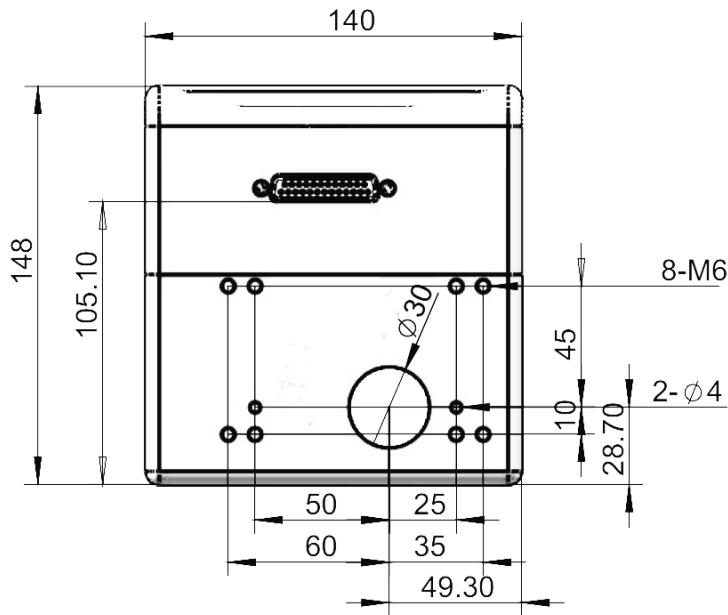

Drawing Beam Entrance Side

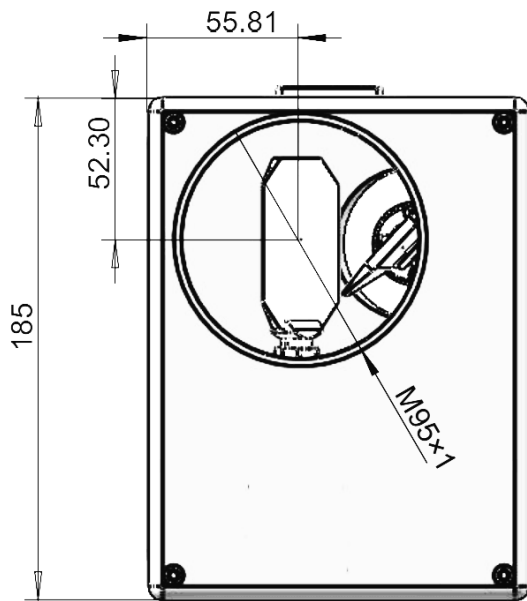

Drawing Beam Exit Side



# Alphabetical Index

<b>2</b>	
20 bit position data.....	10
2D.....	8
<b>B</b>	
Backchannel.....	10
<b>C</b>	
Condensing.....	6
Correction table.....	10
Corrosive.....	6
<b>D</b>	
Dimensions.....	13ff.
Distortion.....	10
Dust.....	6
<b>E</b>	
E1803D.....	11
<b>F</b>	
F-Theta.....	10
<b>H</b>	
Humidity.....	6
<b>L</b>	
Linear.....	10
<b>M</b>	
Maximum Laser Power.....	8
Mirror size.....	8
<b>N</b>	
NX-02.....	7f.
<b>P</b>	
Power supply.....	8, 11
<b>R</b>	
Resolution.....	8
<b>S</b>	
Scale drift.....	9
Scanning angle.....	8
<b>T</b>	
Temperature.....	9
<b>V</b>	
Vibrations.....	6
<b>W</b>	
Water cooling.....	9
Weight.....	9
<b>X</b>	
XY3_CMD_AUTOCALIB_OFF.....	10
XY3_CMD_AUTOCALIB_ON.....	10
XY3_CMD_TEMPCOMP_OFF.....	10
XY3_CMD_TEMPCOMP_ON.....	10
XY3-100.....	7f., 11
XY3-100 features.....	10

**Z**

Zero drift.....9